

Implementing Intelligent Techniques for the Advanced Alarm Processing

Yufan Guan and Mladen Kezunovic

Department of Electrical and Computer Engineering

Texas A&M University

College Station, USA, 77843-3128

carling@tamu.edu and kezunov@ece.tamu.edu

Abstract—A major power system disturbance could trigger hundreds and sometimes thousands of individual alarms and events. A better and simpler description of the problems affecting the power system is an urgent need for the operators. The task of an Intelligent Alarm Processor (IAP) is to analyze thousands of alarm messages and extract the information that explains cause-effect sequences associated with the network events. In this sense, Fuzzy Reasoning Petri-nets is a very powerful intelligent technique to deal with the complexities of the power system fault and alarm processing. A graphical FRPN model is build in this paper based on the optimal structure and uses fuzzy logic parameters to effectively tackle the uncertainties. Case studies are presented to demonstrate the capability of the IAP under real fault scenarios.

Keywords- Alarm Processing, Fuzzy Reasoning, Petri-nets, Power Systems, Intelligent Techniques

I. INTRODUCTION

ALARM processing has been a traditional feature of the power system Energy Management System (EMS) and has been studied over the past decades. Despite variety of proposed solutions, operators still have a strong need for a better way to monitor the system than what is provided by the existing alarm processing software [1]. An EPRI study [2] has listed issues that operators face with alarms during their day-to-day operation of a power system:

- Alarms which are not descriptive enough
- Alarms which are too detailed
- Too may alarms during a system disturbance
- False alarms
- Multiplicity of alarms for the same event
- Alarms changing too fast to be read on the display
- Alarms not in priority order

Operators are expected to monitor the system condition and take actions immediately after the alarms occur. However, when all problems mentioned above mix up, operators are severely restrained to perform properly in a timely manner.

In the recent years, a lot of efforts about the concepts of filtering and suppressing alarms based on the intelligent techniques have been used in many practical systems [3]. Those major intelligent techniques used so far include:

a. Expert System (ES) technique

Expert system (ES) technique [4-7] is well suited for a diagnosis problem like fault section estimation because it mimics the behavior of fault analysis experts which perform fact-rule comparisons and search of consequent steps. The disadvantage is that an expert system has to be developed using formalized knowledge that correctly captures the expertise, which may require an extensive expert interviewing effort.

b. Fuzzy Logic (FL) technique

FL technique [8,9] offers a convenient means for modeling inexactness and uncertainties, hence a powerful solution to handle the imprecise and incomplete data may be implemented. The disadvantage is the need to have empirical data that helps determine the membership function and properties of fuzzy variables.

c. Petri-nets (PN) technique

Petri-nets (PN) based technique [10-13] possesses the characteristics of graphical discrete event representation and parallel information processing. While very fast, the dynamic nature of the temporal change of the alarms cannot be easily captured with the standard Petri-net approach unless further adjustments are made.

d. Fuzzy Reasoning Petri-nets (FRPN) technique

Fuzzy Reasoning Petri-nets (FRPN) technique [14-16] gains the advantages of Expert System and Fuzzy Logic, as well as parallel information processing. Some of the disadvantages of previously mentioned individual techniques may be offset by the benefits coming from combining the techniques.

An implicit disadvantage of the traditional knowledge-based systems is that they may be incapable of handling complex scenarios that are not encountered during knowledge acquisition, implementation, or validation. They may also suffer from the slowness in analysis due to involved knowledge representation and inference mechanism. Solutions based on discrete event view of Petri-nets also have several limitations. For instance, the number of initial inputs is limited and it is difficult to model inexactness and uncertainties. Consequently, to accurately identify fault sections under complex circumstances, substantial heuristic rules and information are additionally required [17].

This paper proposes an advanced Fuzzy Reasoning Petri-nets (FRPN) diagnosis model after the structure adopted in [17]. This Intelligent Alarm Processor (IAP) model is expected to achieve the following goals:

- Suppress multiple alarms from one event
- Generate a single conclusion through logical cause-effect relationship
- Automate the process to get answers quickly
- Make graphical and numerical information concise and easy to follow

The proposed approach introduces novel techniques for achieving efficiency and speed in alarm processing developed by using SCADA data and additional data obtained from substation intelligent electronic devices (IEDs). A real fault case that happened in Texas, USA on September 2007 is used to test the model.

Paper starts with an introduction of the proposed technique in section II and elaborates on the description of the actual case used in this study in section III. Required modeling and case study results are given in subsequent sections. Conclusions are given at the end.

II. FUZZY REASONING PETRI-NETS

A. Definition

Paper [16] has defined Fuzzy Reasoning Petri-nets (FRPN) as an 8-tuple.:

$$(P, R, I, O, H, \theta, \gamma, C)$$

where

- 1) $P = \{p_1, p_2, \dots, p_n\}$ is a finite set of places or called propositions.
- 2) $R = \{r_1, r_2, \dots, r_m\}$ is a finite set of transitions or called rules.
- 3) $I : P \times R \rightarrow \{0,1\}$ is an $n \times m$ input matrix defining the directed arcs from propositions to rules. $I(p_i, r_j) = 1$, if there is a directed arc from p_i to r_j , and $I(p_i, r_j) = 0$, if there is no directed arcs from p_i to r_j , for $i = 1, 2, \dots, n$, and $j = 1, 2, \dots, m$.
- 4) $O : P \times R \rightarrow \{0,1\}$ is an $n \times m$ output matrix defining the directed arcs from rules to propositions.
- 5) $H : P \times R \rightarrow \{0,1\}$ is an $n \times m$ matrix defining the complementary arcs from propositions to rules. $H(p_i, r_j) = 1$, if there is a complementary arc from p_i to r_j , and $H(p_i, r_j) = 0$, if there is no directed arcs from p_i to r_j , for $i = 1, 2, \dots, n$, and $j = 1, 2, \dots, m$.
- 6) θ is a true degree vector. $\theta = (\theta_1, \theta_2, \dots, \theta_n)^T$, where $\theta \in [0,1]$ means the truth degree of p_i , $i = 1, 2, \dots, n$. The initial truth degree vector is denoted by θ^0 .

7) $\gamma : P \rightarrow \{0,1\}$ is a marking vector. $\gamma = (\gamma_1, \gamma_2, \dots, \gamma_n)^T$. $\gamma_i = 1$, if there is a token in p_i , and $\gamma_i = 0$, if p_i is not marked. An initial marking is denoted by γ^0 .

8) $C = \text{diag}\{c_1, c_2, \dots, c_m\}$. c_i is the confidence of r_i , $j = 1, 2, \dots, m$.

The 5-tuple (P, R, I, O, H) is the basic FRPN structure that defines a directed graph. The updates of the truth degree vector θ through execution of a set of rules describe the dynamic reasoning process of the modeled system. If the truth degree of a proposition is known at a certain reasoning step, a token is assigned to the corresponding proposition, which is associated with the value between 0 and 1. The token is represented by a dot. When a proposition p_i has no token, which means that the truth degree is unknown at that step, $\theta_i = 0$.

B. Execution Rules

In order to describe the execution rules of a FRPN, the following operators are used:

1) $\oplus : A \oplus B = D$, where A, B, and D are all $m \times n$ - dimensional matrices, such that $d_{ij} = \max\{a_{ij}, b_{ij}\}$.

2) $\otimes : A \otimes B = D$, where A, B, and D are all $(m \times p)$, $(p \times n)$, $(m \times n)$ - dimensional matrices, such that $d_{ij} = \max_{1 \leq k \leq p} \{a_{ik} \cdot b_{kj}\}$.

The execution rules include enabling and firing rules.

- 1) A rule $r_j \in R$ is enabled if and only if p_i is marked, or $\gamma_i = 1, \forall p_i \in \{\text{input propositions of } r_j\}$.
- 2) Enabled at marking γ , r_j firing results in a new γ' .

$$\gamma'(p) = \gamma(p) \oplus O(p, r_j), \quad \forall p \in P$$

The truth degree vector changes from θ to θ'

$$\theta'(p) = \theta(p) \oplus c_j \cdot \rho_j \cdot O(p, r_j), \quad \forall p_i \in P$$

where

$$\rho_j = \min_{p_i \in r_j} \{x_i \mid x_i = \theta_i, \text{ if } I(p_i, r_j) = 1;$$

$$x_i = 1 - \theta_i \text{ if } H(p_i, r_j) = 1\}$$

and

$$r_i = \{p_i \mid I(p_i, r_j) = 1 \text{ or } H(p_i, r_j) = 1, p_i \in P\}$$

- 3) All the enabled rules can fire at the same time. A firing vector μ is introduced such that $\mu_j = 1$, if r_j fires. After firing a set of rules, the marking and truth degree vectors of the FRPN become

$$\gamma' = \gamma \oplus [O \otimes \mu] \quad (1)$$

$$\theta' = \theta \oplus [(O \cdot C) \otimes \rho] \quad (2)$$

where

$\rho = (\rho_1, \rho_2, \dots, \rho_m)^T$, which is called control vector.
 $\mu : T \rightarrow \{0, 1\}$ is the firing vector.

III. CASE DESCRIPTION

A. Background

On September 5th 2007, a tornado in the area resulted in the tripping of two 345 kV lines and two generators in one of the substations. As a result of the unit trips, the bus split into two buses due to the configuration of the substation. Two cases taken from the Supervisory Control and Data Acquisition (SCADA) database that was used by the EMS to monitor the area are used. The first was captured at approximately 07:49 AM, before the event occurred, and the second was captured at approximately 07:54 AM, just after the event occurred.

B. Current Alarm Processing Solutions

The control center is equipped with an alarm processor that helps operators deal with various operating contingencies. A major power system disturbance could trigger hundreds and sometimes thousands of individual alarms and events. The following is a typical screen shot that the operators usually see in the control center.

Fig. 1. Alarm Screen Shot

For the case in question, there were 2125 alarm messages that appeared within only 45 minutes. Obviously it is beyond the capacity of any operator to handle. Thus, operators may not be able to respond to the unfolding events in time, and even worse, the interpretation by the operators may be either wrong or inconclusive. Operators also admitted that the list of large number of alarms provide little help for them.

IV. MODEL ESTABLISHMENT IMPLEMENTING FRPN

A. Power System Configuration

The alarm diagnosis algorithm and model used for this case are illustrated in an earlier paper [17]. The protection system configuration for this case is shown in Fig. 2.

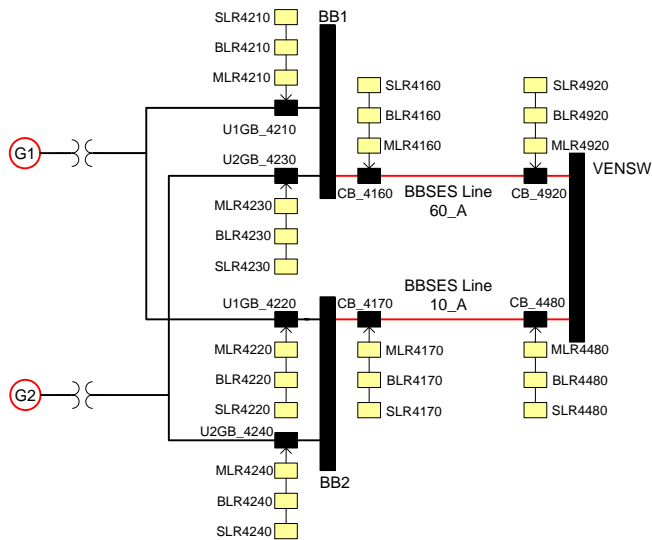

Fig. 2. Protection System Configuration Diagram

The system consists of 9 sections, including 3 buses, 2 generators and 4 transmission lines.

When one or more faults occur on certain sections of the power system, protection devices will reach certain status accordingly. The observed circuit breaker status signals obtained from RTUs of SCADA systems are used as inputs for estimation of the faulted sections. The logic reasoning method uses the relay status obtained from the online-database to validate each candidate fault section. The strategy is to build one FRPN diagnosis model for each section of the power system. Each model establishes reasoning starting from a set of SCADA data to the conclusion of fault occurrence on its associated section with certain truth degree value.

We use backward reasoning concept to structure the FRPN diagnosis models and generalize the design for transmission lines and buses. Fig. 3 and Fig. 4 illustrate backward reasoning concept for structuring transmission line and bus diagnosis models respectively [17]. The ‘AND-OR’ structure concisely represents all the possible combinations of main, primary backup and secondary backup protection operations for inferring a fault.

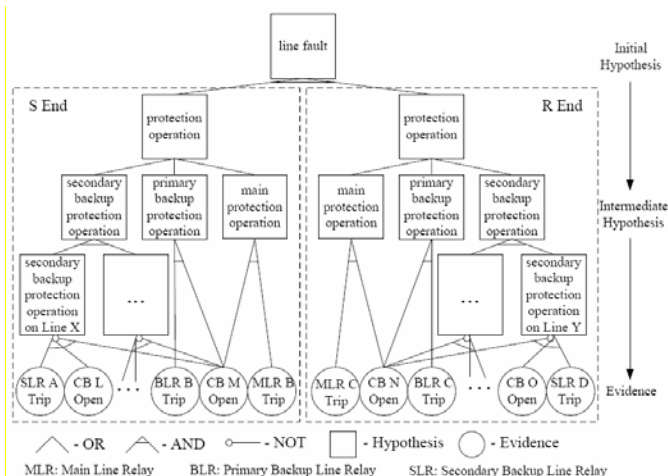

Fig. 3. Backward Reasoning Concept for Structuring Transmission Line Diagnosis Models

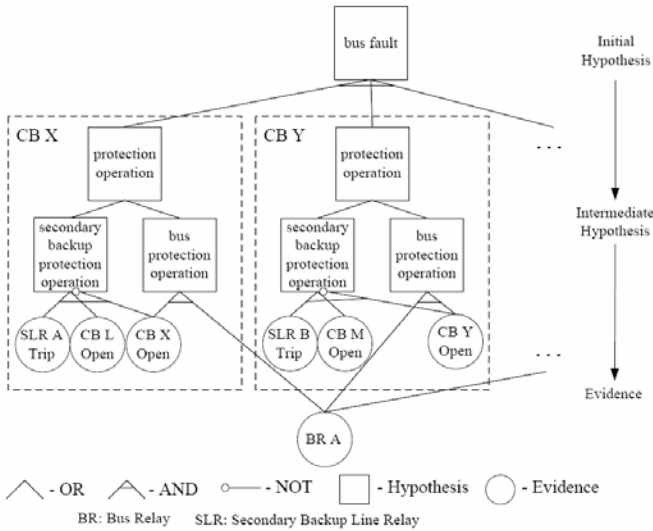

Fig.4. Backward Reasoning Concept for Structuring Bus Diagnosis Models

Based on the proposed structure introduced earlier [17], all the FRPN diagnosis models are developed. As examples, Fig. 5 and Fig. 6 show the FRPN models for the transmission line BBSSES_60A and Unit 1 respectively.

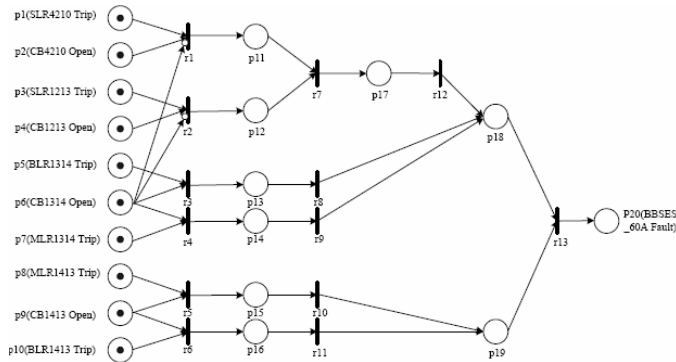

Fig.5. A FRPN Model for BBSSES_60A Fault

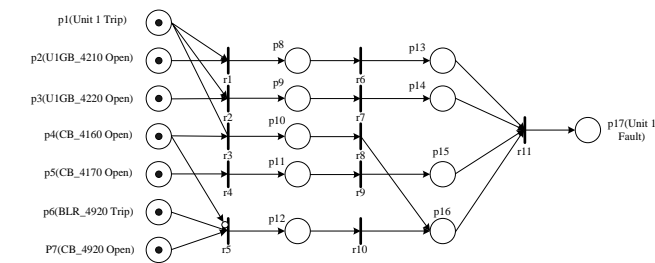

Fig.6. A FRPN Model for Unit 1 Fault

Each proposition is given a “truth degree value” to illustrate the strength of confirmation. We use a “weighted average” operation when calculating the truth degree value of a consequent proposition from the truth degree values of its antecedent propositions. Fig. 7 illustrates the operation for r1 in Fig. 5.

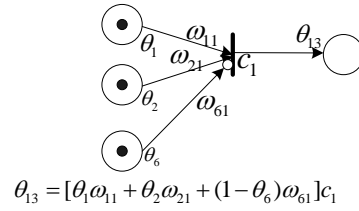

Fig.7. An Example of “Weighted Average” Operation

The “weighted average” operation has two benefits [17]. First, the relative significance of antecedent propositions in implicating the consequent proposition is recognized by the weights of antecedent propositions. This is particularly meaningful when the cause-effect relation among antecedent propositions is considered. In our assumption, circuit breaker opening is the effect of relay trip. The “circuit breaker opens” proposition is generally given larger weight than that of the “relay trips” proposition because circuit breaker opening indicates the completion of a protection operation more directly. For example, regarding the rule r3 in Fig. 6, the proposition p5 “BLR4160 Trip” will be given a weight 0.4; the proposition p6 “CB4160 Open” will be given a weight 0.6.

Second, the false data problem is effectively handled by averaging the truth degree values of antecedent propositions. For example, when the relay MLR4160 trips and the circuit breaker CB4160 opens as a consequence of a fault on the line BBSSES_60A, and “MLR4160 Trip” is not observed, p15, which stands for “main protection operates”, will still get a moderate truth degree value instead of 0, hence a moderate truth degree value for the final conclusion. It is apparent that the larger the number of input data, the impact of false data is more effectively countered.

V. CASE STUDY

Though the operator in this case was not able to provide relay data, our algorithm still works by having only SCADA data as inputs.

A. Simulation Results

CASE 1: No protective relay signals. Circuit breaker CB4210, CB4220, CB4160, CB4920 status changes are detected.

Diagnosis result: Line BBSSES_60A is faulted, and its truth value is 0.5130.

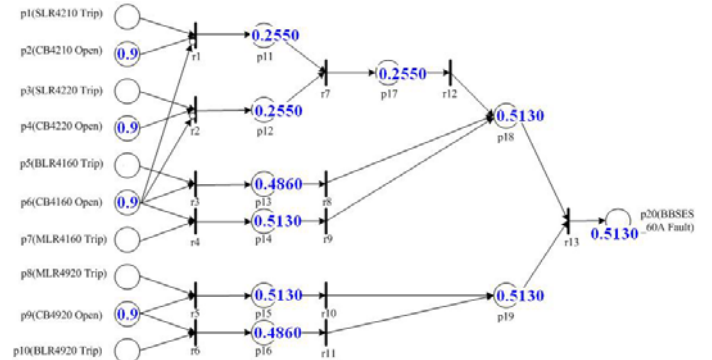

Fig.8. FRPN Model Analysis Procedure for Line BBSSES_60A

CASE 2: This report assumes the operation of the circuit breaker is tripped by the associated relays, thus allowing the relay status to be obtained to validate the fault. We assumed that we received the relay signals related to this case. All the devices worked correctly with no false signals. Circuit breaker CB4210, CB4220, CB4160, CB4920 are detected.

Diagnosis result: Line BBSES_60A is faulted, and its truth value is 0.8550. With the input of the related relay signals, the fault certainty has been increased dramatically.

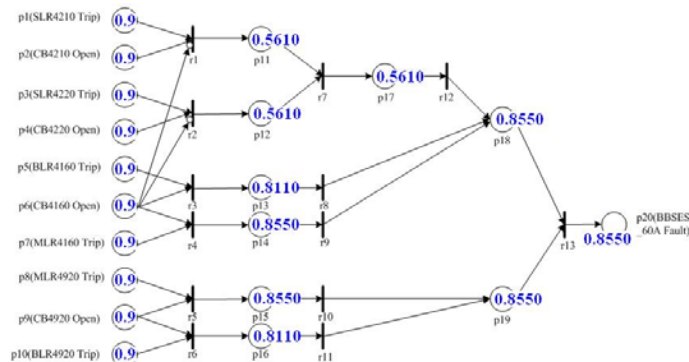

Fig.9. FRPN model analysis procedure for Line BBSES_60A_with_assumed_relay_data

CASE 3: No protective relay signals. Unit 1 tripped, and circuit breaker CB4210, CB4220, CB4160, CB4170, CB4920 are detected.

Diagnosis result: Unit 1 is faulted, and its truth value is 0.8550.

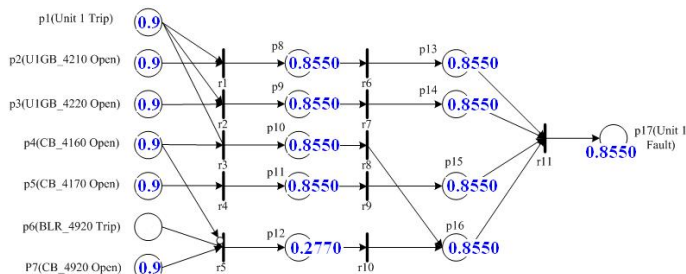

Fig.10. FRPN Model Analysis Procedure for Unit 1

B. Discussion

From the simulation test, we may draw the conclusion that by using only SCADA data, our proposed Intelligent Alarm Processor model still works properly for the practical cases. Here is a list for the comparison between existing and our solutions:

| | Existing | TEES |
|----------|---|---|
| Method | Use the Alarm Browser priority groupings and search through the EMS one line diagrams to check flows and other system parameters manually | Use IAP system and generate the fault analysis report automatically |
| Time | Time consuming | Within seconds |
| Accuracy | Not applied | Without relay inputs Certain |
| | | With relay inputs Very Certain |

In practice, the weight factors need to be assigned through collaboration of the experienced operators and maintenance staff, who are especially familiar with the importance and reliability of each component in the power system of interest.

To reduce the operators' burden, the ultimate screen in the control center will not show any redundant numerical truth degree factors or alarm messages. Instead, a final fault analysis result and some possible recommendations will pop up to help the operators to make a quick decision. On the other hand, the intermediate cause-effect analysis procedure is available any time the operators are ready to monitor it.

VI. CONCLUSION

From the review of the existing intelligent techniques used for Alarm Processing, it was concluded that existing solutions have both advantages and disadvantages hence new approach is needed to eliminate disadvantages.. Simulation results from our approach tested using real fault scenario case confirms the feasibility and advantages of the proposed Intelligent Alarm Processor. In summary, compared with current solutions, our model has the following advantages:

- The fault alarm analysis report can be generated automatically and immediately after the fault occurs.
- The FRPN models can be built in advance based on power system and protection system configurations and stored in files. In such a way, the FRPN models can be easily modified according to the changes of input data as well as power system and protection system configuration.
- This solution can use only SCADA data and does not need detailed data from IEDs or other measurement devices.
- Further improvement could be made by incorporating protective relay data, which will greatly increase the accuracy even with missing or false alarm signals.

ACKNOWLEDGMENT

The authors wish to acknowledge the support from ERCOT personnel Mr. John Adams, Mr. Diran Obadina, Mr. John Dumas, Mr. Richard Howard, Mr. Ken McIntyre, Mr. Chad Thompson and Ms. Thuy Huynh. Special recognition for the work reported in this paper is due to the former TAMU graduate students (now with ERCOT) Dr. Xu Luo for the initial development of FRPN.

REFERENCES

- [1] Bruce F. Wollenberg, "Feasibility Study for an Energy Management System Intelligent Alarm Processor", *IEEE Trans. Power Systems*, vol. PWR-1, no. 2, pp: 241-246, May 1986.
- [2] EPRI EL. *Human Factors Review of Electric Power Dispatch Control Centres*, vols 1-6. Electric Power Research Institute, Palo Alto, CA.
- [3] M. Pfau-Wagenbauer and W. Nejdil, "Integrating model-based and heuristic features in a real-time expert system," *IEEE Expert*, pp. 12-18, August 1993.
- [4] A. A. Girgis and M. B. Johns, "A hybrid expert system for faulted section identification, fault type classification and selection of fault location algorithms," *IEEE Trans. Power Delivery*, vol. 4, no. 2, pp. 978-985, April 1989.
- [5] Y.L. Zhu, Y.H. Yang, B.W. Hogg, W.Q. Zhang, and S. Gao, "An expert system for power systems fault analysis," *IEEE Trans. Power Systems*, vol. 9, no. 1, pp. 503-509, February 1994.
- [6] E. M. Vazquez, O. L. M. Chacon, and H.J.F. Altuve, "An on-line expert system for fault section diagnosis in power systems," *IEEE Trans. Power Systems*, Vol. 17, no. 2, pp. 439-444, May 2002.
- [7] Y. C. Huang, "Fault section estimation in power systems using a novel decision support system," *IEEE Trans. Power Systems*, vol. 17, no. 2, pp. 439-444, May 2002.
- [8] H. J. Cho and J. K. Park, "An expert system for fault section diagnosis of power systems using fuzzy relations," *IEEE Trans. Power Systems*, vol. 12, no. 1, pp. 342-348, February 1997.
- [9] W. H. Chen, C. W. Liu, and M. S. Tsai, "On-line fault diagnosis of distribution substations using hybrid cause-effect network and fuzzy rule-based method," *IEEE Trans. Power Delivery*, vol. 15, no. 2, pp. 710-717, April 2000.
- [10] K. L. Lo, H. S. Ng, and J. Trecat, "Power systems fault diagnosis using Petri nets," *IEE Proc. Generation, Transmission and Distribution*, vol. 144, no. 3, pp. 231-236, May 1997.
- [11] K. L. Lo, H. S. Ng, D. M. Grant, and J. Trecat, "Extended Petri-net models for fault diagnosis for substation automation," *IEE Proc. Generation, Transmission and Distribution*, vol. 146, no. 3, pp. 229-234, May 1999.
- [12] A. A. E. Fergany, M. T. Yousef, and A. A. E. Alaily, "Fault diagnosis of power systems using binary information of breakers and relays through DPNs," in *Proc. International Conference on Power System Technology - PowerCon*, vol. 2, Kunming, China, October 2002, pp. 1122-1126.
- [13] H. Ren, Z. Q. Mi, H. S. Zhao, and Q. X. Yang, "Fault diagnosis for substation automation based on Petri nets and coding theory," in *Proc. IEEE Power Engineering Society General Meeting*, vol. 1, Denver, CO, June 2004, pp. 1038-1042.
- [14] S. M. Chen, J. S. Ke, and J. F. Chang, "Knowledge representation using fuzzy Petri nets," *IEEE Trans. Knowledge and Data Engineering*, vol. 2, no. 3, pp. 311-319, September 1990.
- [15] T. V. Manoj, J. Leena, and R. B. Soney, "Knowledge representation using fuzzy petri nets c revisited," *IEEE Trans. Knowledge and Data Eng.*, vol. 4, no. 10, pp. 666-667, July 1998.
- [16] M. M. Gao, M. C. Zhou, X. G. Huang, and Z. M. Wu, "Fuzzy reasoning Petri nets," *IEEE Trans. Systems, Man and Cybernetics*, Part A, vol. 33, no. 3, pp. 314-324, May 2003.
- [17] Xu, L; Kezunovic M. "Implementing Fuzzy Reasoning Petri-nets for Fault Section Estimation," *IEEE Trans. Power Delivery*, vol. 1, no. 1, November 2006.

BIOGRAPHIES

Yufan Guan (S'06) received his B.S. degree from Zhejiang University, Hangzhou, China, in 2007. He is currently pursuing his Ph.D. degree from Texas A&M University, College Station, USA. His research interests are alarm processing, substation automation and artificial intelligence applications in power systems.



Mladen Kezunovic (S'77-M'80-SM'85-F'99) received the Dipl. Ing., M.S. and Ph.D. degrees in electrical engineering in 1974, 1977 and 1980, respectively. Currently, he is the Eugene E. Webb Professor and Site Director of Power Engineering Research Center (PSerc), an NSF I/UCRC at Texas A&M University. He worked for Westinghouse Electric Corp., Pittsburgh, PA, 1979-1980 and the Energoinvest Company, in Europe 1980-1986. He

was also a Visiting Associate Professor at Washington State University, Pullman, 1986-1987 and The University of Hong Kong, fall of 2007. His main research interests are digital simulators and simulation methods for relay testing as well as application of intelligent methods to power system monitoring, control, and protection. Dr. Kezunovic is a member of CIGRE and Registered Professional Engineer in Texas.