

## Use of Digital Fault Recorder Files for Protective Relay Evaluations

M. Kezunovic, V. Skendzic  
Texas A&M University  
College Station, Texas

L. L. Mankoff  
Electric Power Research Institute  
Palo Alto, California

### I. INTRODUCTION

A typical approach to protection relay evaluations under transient conditions has been to use analog power system simulators. Recently, hybrid (analog/digital) and all digital simulators have been developed for transient studies.

Digital simulators can use the outputs of EMTP studies or the digital fault recording of actual system faults. These files are replayed into the relays for the purpose of their evaluation. A waveform reconstruction system is needed to provide analog waveforms from the digital files recorded by DFRs, or produced by EMTP studies.

This paper describes an approach of using DFR files for relay evaluation. A digital simulator facility developed at Texas A&M University (TAMU) is utilized for this purpose [1,2]. Required hardware and software expansion is funded jointly by the Electric Power Research Institute (EPRI) and some member utilities [3].

The first part of the paper states objectives of the EPRI - funded study. A brief description of the DYNA-TEST digital simulator design, implemented at Texas A&M University, is given next. An overview of the requirements for fault recording and replaying is also provided. Finally, description of the DFR interfacing and file management software, developed for utilization of DFR files in relay evaluations is outlined.

### II. OBJECTIVES OF THE EPRI-FUNDED STUDY

The ongoing R&D effort, funded by an EPRI contract with added support from some of its member utilities, is scheduled for completion by about year-end 1991 and has the following objectives:

- a. Development of simulator guidelines
- b. Application of EMTP and DFR files
- c. Specification of test cases.

A brief description of each of the objectives is provided below. The topic of this paper

is related to the use of DFR files for relay evaluations, while the EMTP applications are discussed elsewhere [1,2,3].

**a.) Development of Simulator Guidelines**

These guidelines are intended to provide to a utility information helpful for procuring a digital simulator either through in-house design and construction or by purchase from a supplier. Additionally, it can help a utility evaluate an offsite facility it may choose to use for relay studies - a facility at some third party or at a relay supplier.

The guidelines are not intended as a design handbook but will be a compilation of key performance parameters along with a review of experiences gained from digital simulator installations at utilities, Texas A&M University and others. It will recognize that alternative technical approaches can be employed to provide digital simulation for relay studies and will aid a utility should it choose to build, buy or use an available facility.

**b.) Application of EMTP and DFR Files**

This activity is related to the use of the Electromagnetic Transient Program (EMTP) or Digital Fault Recorder (DFR) output files for protection relay evaluation studies. Therefore, the following issues had to be resolved:

- EMTP applications for relay studies
- DFR file format processing.

EMTP applications for relay studies include evaluation of the level of EMTP complexity required for specific relay studies. Key questions include the detail of representation of a transmission line under study, source and "external" system modeling for relay needs, etc. The need for frequency dependent modeling of power system elements for relay studies will also be evaluated.

Digital models of relay input sources are required for the development of EMTP files for relay studies. A review of available models for CTs, PTs and CCVTs will be conducted to evaluate their suitability for relay studies. Particular attention will be paid to accurate representation of effects such as iron saturation, which can cause waveform distortion affecting relay performance.

DFR file format processing is required before the recorded files are made suitable for replaying in a simulator. This study is to produce software needed to perform the required processing. The file format processing includes file format conversion, sample rate conversion, and file management functions. This software should run in both UNIX and DOS environments. Selection of the DFR products to be supported was made by the EPRI utility advisors. Development of the software should be based on the related standards [4].

### c.) Specification of Test Cases

Another objective of the EPRI/TAMU effort is to provide a series of test cases which will help in the data interchange in protective system studies between utilities and suppliers. This is envisioned as detailed data, probably stored on disk, for typical faults for a number of power system configurations. Some of these test cases will be synthesized as representative of typical configurations; others will be actual, complex cases solicited from utilities.

As now planned, test cases for facility verification will be implemented on a digital simulator and output waveforms will be recorded with a specific burden representative of a typical relay configuration. Comparison of the output waveform of the digital simulator to a reference waveform would be used to verify that digital simulator facilities are in agreement even though simulator design details may differ.

### III. DYNA-TEST SIMULATOR CHARACTERISTICS

Detailed description of the DYNA-TEST simulator design being implemented at Texas A&M University is given in several publications [1,2,3]. Discussion given in this paper provides a brief overview of the following simulator design characteristics:

- a. Simulator architecture
- b. Hardware subsystems
- c. Software modules.

#### a.) Simulator Architecture

Details of the system architecture are shown in Figure 1.

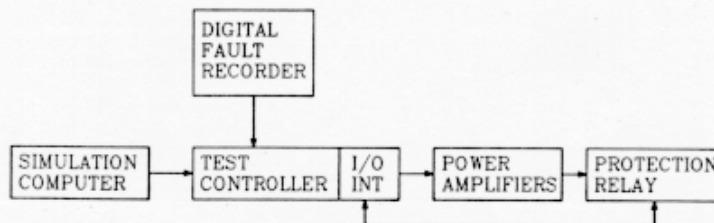

Figure 1. System Architecture

As it can be observed from Figure 1, there are two sources of test signals. One is a simulation computer, which hosts the fault simulation program. The other is a Digital Fault Recorder (DFR), which captures records of the fault signals in a substation.

Both sources provide their signals in digital form, enabling easy file transmission to the test controller. The controller is mainly in charge of analog test signal generation. This is done through the dedicated D/A converter interface followed by the appropriate interpolation filters. These analog signals are then fed to the power amplifiers in order to increase their power level. Finally, test signals are injected to the relays. The controller also has a dedicated digital I/O interface used to communicate contact signals which are also need and/or generated by the relays.

### b.) Hardware Subsystems

The hardware subsystems are shown in Figure 2.

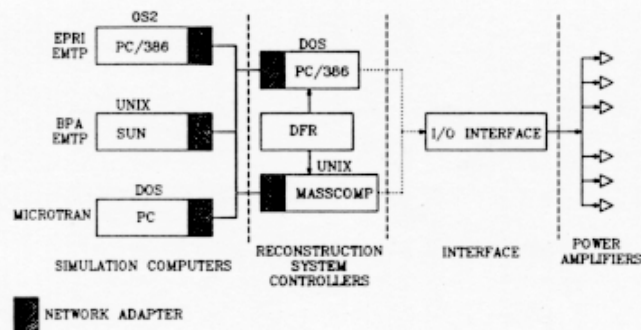

Figure 2. DYNA-TEST Hardware Configuration

As it can be seen from Figure 2, hardware subsystems are:

- Computers for EMTP simulations
- Waveform reconstruction controllers
- Controller I/O interface
- Power amplifiers.

It should be noted that the DYNA-TEST simulator configuration includes a number of optional computers that are provided for various studies. The utility-tailored configuration would be much simpler. It may be implemented using only one computer for both EMTP simulations and DFR interfacing. The same computer may also be used as the controller for the signal waveform reconstruction.

Computers for EMTP simulations are selected in the EPRI study to represent various EMTP installations covering OS/2, UNIX and DOS environments. This is provided to investigate output file formats for different EMTP packages.

Waveform reconstruction controllers are selected to support both UNIX and DOS environments. All of the file conversion software and file management software developed in this project will be made compatible with both environments.

Controller I/O interface is custom designed since there is no appropriate product on the market at this time. Again, the I/O interface design is compatible with both UNIX and DOS machines.

Power amplifiers are going to be purchased from an outside vendor. Preliminary investigation of the commercial market has shown that there are a number of different amplifier products that could be used for the DYNA-TEST simulator design. Detailed amplifier testing and evaluation is under way to determine amplifier characteristics. Typical amplifier requirements are given in Table I.

### c.) Software Modules

The basic software organization is given in Figure 3. As it can be observed, several EMTP packages are used. These packages are available from different sources [5,6,7]. DFR files are generated using commercial software provided by the DFR vendors. I/O driver software is also available as a commercial product. Instrument transformer modeling software is being developed as a part of the project. However, it is not further discussed in this paper.

Table I. Typical Power Amplifier Requirements

Design Features	Voltage Amplifiers	Current Amplifiers
Output Voltage	> 200 V	> 60 V
Output Current	> 0.1 A	> 140 A
Power Dissipation	> 30 W	> 400 W
Power Dissipation (200mS MIN)	> 30 W	> 4000 W
Frequency Response ( $\pm 0.2$ dB)	D. C. to 7 kHz	D. C. to 7 kHz
T. H. D.	< 0.2%	< 1%

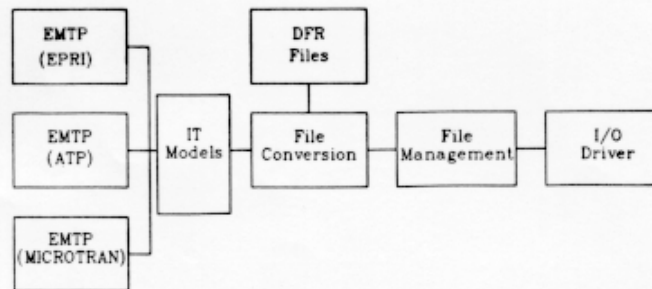

Figure 3. Software Organization

The main interest of this paper is the file conversion and file management software. This software is being developed in this project. A detailed description of the software features is given in the Section V. Issues associated with specification of the software requirements are discussed below.

#### IV. FAULT RECORDING AND REPLAYING

This section deals with the main issues related to usage of Digital Fault Recorder (DFR) files in protective relay testing and evaluation. Issues are divided into three major groups:

- a. Recording hardware
- b. Recording practice
- c. Waveform reconstruction

The following discussion tries to point out potential pitfalls in using presently available DFR data. The issues are related to the understanding of recording equipment capabilities and engineering practice needed to ensure the data precision and consistency required for meaningful relay testing.

##### a.) Recording Hardware

The number of DFRs installed in the field has been steadily increasing during the past few years. So has the understanding of power system transients, and the methods for their recording. After carefully analyzing the existing fault libraries, one can conclude that only a few, if any, of the records can qualify for relay testing. The main hardware related problems often found in the DFR files are:

- Aliasing
- Input signal filtering

- Sampling instant skew
- Records with multiple sampling frequencies.

Aliasing is a well known phenomena related to any analog signal time discretization (sampling) process. It can be avoided if the signal being sampled is band limited, and sampling frequency is chosen to be at least two times higher than the highest frequency component contained in the signal. The finite bandwidth requirement is usually imposed by means of additional low pass filtering at the input. Some of the currently available DFRs do not provide adequate input channel filtering, relying on the filtering properties of the power system itself. While this arrangement may hold for some faults, it is ambiguous in the general case. This leaves the protection engineering with the task of selecting the appropriate input sampling frequency and later judging whether a given record is corrupted by aliasing effects.

In some cases, analog low-pass input signal filtering is available or can be added externally. In that case, additional care should be given to the phase characteristics of the filter used and the phase matching among different channels. Linear phase inside the recording bandwidth and tight matching between the channels are mandatory in order to preserve the mutual edge positioning relations.

The usual assumption made about DFR records is that all of the input channels are sampled at the same instant. However, some of the older designs may utilize a single Sample & Hold (S&H) circuit, resulting in the sampling instant skew between different channels. This is due to the multiplexing arrangement that switches different input channels to the same S&H and A/D circuits. Also, in some cases skew is not constant or can not be exactly quantified due to the specific design features.

Some recorders generate the output records with multiple sampling frequencies. This is due to the use of waveform compression techniques, implemented by adaptively lowering the sampling frequency. Although justified by savings in the required data storage space, this technique calls for special detection and processing in order to prepare the waveform for relay testing purposes.

To conclude, DFR records being used for protection relay evaluation should be free of aliasing effects. Sampling frequencies higher than 3kHz are recommended in order to capture the most interesting transient phenomena. In cases when only wide-band input filtering is provided, it is advisable to use a higher sampling rate. Sampling instant skew and change of sampling frequency in the record, may not be too problematic to deal with. Nevertheless, they should be avoided if possible, especially if tests are to be performed on fast state of the art microprocessor based relays.

#### **b.) Recording Practice**

Some of the common recording errors can be avoided by properly operating the equipment. Major problems in this group are:

- Input signal scaling
- Sampling rate selection
- Prefault record length
- Channel extraction
- Input channel cross talk.

Input signal scaling is primarily related to the DFR effective resolution. Although the system resolution appears to be the best understood system parameter, it is however, hard to reach the agreement upon the minimum level of precision required in power system applications.

Let us try to clarify this by using an example. Assume that a system engineer decides to record the current transients with peak values up to  $20 * I_n$ . Assuming an ideal 10 bit system, this leaves one with approximately 5 bits resolution in the prefault portion of the waveform if one requires 2% error for this time interval. This is shown by the following equation:

$$\text{resolution} = \log_2(2^{10}/20)$$

The situation gets even worse if the system is operated below the nominal load level ( $i_n$ ) before the fault occurred. It should not be forgotten that effective system resolution is generally lower than its physical resolution.

The question of properly qualifying the DFR characteristics is described in reference [8]. All this makes the 12 bit physical resolution almost mandatory if a record is to be successfully used for relay testing. Even with this, special attention should be given to input signal scaling in order to maximize the available dynamic range, while avoiding the recorder input clipping. Waveform records containing clipped portions can not be used for testing purposes.

As outlined earlier, sampling rate selection remains difficult to determine. It should be set as high as permitted by the resulting record length. The shortest record length is usually determined by the intrinsic time duration of the fault type being expected on a given system.

Prefault record length should be chosen in such a way as to contain at least 3 to 5 cycles of steady state signal before the fault. In the actual relay testing, this portion of the waveform has to be extended in order to provide the relay with sufficient prefault period. The mentioned prefault record length depends on the prefault waveform parameter identification software and will differ slightly depending on the required level of precision and actual software implementation.



Channel extraction is performed in order to construct a valid set of waveforms required by the tested relay. This may vary but is typically described as a three phase set of voltages and currents. This conflicts with the standard recording practice where only selected signals are recorded (two currents and/or one voltage per transmission line), in order to monitor as much of the substation quantities as possible, with the given number of recorder channels. The missing information **can not** be generated at a later time due to the level of ambiguity associated with transient waveforms.

Input channel cross talk is another potential problem associated with DFR systems. While it can be avoided by providing appropriate input cable shielding and isolation, some of existing installations might not provide sufficient cross talk suppression. This may cause occurrence of some current signal surges that do not correspond to the fault current transients. Closer inspection might reveal correlation of the peaks with fast changing portions of voltage waveforms. Such waveforms can not directly be used for testing.

### c.) **Waveform Reconstruction**

Errors in this group are less known and are partly related to the actual signal reconstruction hardware implementation. This overview tries to point out only the main issues of interest. Most of the features have been, or are being, implemented as a part of the DYNA-TEST simulator constructed at Texas A&M University [3]. Those are:

- Sampling rate conversion
- Polarity check and correction
- DFR contact record creation/editing
- Gain scaling and calibration
- Waveform reconstruction system phase response.

The first problem associated with the digital fault waveform reconstruction is related to the sampling rate conversion requirement. This problem results from the current unavailability of standards, and the wide variety of sampling frequencies being used by different DFRs. In order to support those recorders, the waveform reconstruction system should either provide the variable output sampling frequency option, or facilities for the signal sampling frequency conversion into a set of predefined frequencies. The first approach typically calls for extensive real-time signal processing, while the second utilizes the lower cost off-line signal preprocessing. The theoretical backgrounds of the sampling frequency conversion process are well described in literature, and are summarized in [4]. In addition to supporting the off-line software approach, a new hardware solution enabling the use of variable output sampling frequency is currently being investigated for use in the TAMU Simulator. The system should provide continuously variable sampling frequency within approximately 14 to 1 range with out-of-band frequency component suppression in the 80 dB range.

Due to the possible DFR wiring mistakes, it is fairly hard to identify a correct trace of the recorded signal polarity. This makes the polarity check and correction mandatory in order to faithfully reproduce the actual current/voltage sequence to the relay. In solving this problem, one can develop a software tool which aids the operator in identifying and correcting the potential polarity inversion. The operator is still left with the decision on how to act in specific cases. The decisions should be based on the additional information available from the field.

One of the ideas being implemented in the DYNA-TEST simulator covers the far end protection schemes and communication equipment function simulation by replaying a set of digital contacts simultaneously with the analog waveform. In order to support this function, an additional DFR contact record creation/editing function is required. A graphic oriented software support is provided for existing digital trace selection and editing. Arbitrary data patterns can also be created for testing purposes or in order to supplement missing field information.

Gain scaling and calibration is related to the overall reconstruction system precision limitations. The solution of this problem requires tightly matched hardware/software support. The gain scaling function can generally be implemented in two ways: by providing the computer controlled gain selection hardware, or by utilizing an extended precision Digital to Analog Converter (DAC). After evaluation, the second approach was chosen for implementation. The DYNA-TEST simulator uses a high precision 16 bit DAC while targeting the 12 bit effective system resolution. Excess resolution is utilized primarily for gain scaling and system calibration purposes. This enables the required level of precision to be achieved and maintained throughout the system operation.

Waveform reconstruction system phase response is an important parameter related to the overall transient reproduction accuracy. The phase response being addressed here covers not only the phase characteristics of the waveform reconstruction filter but also the delays introduced by the high power output amplifiers and signal processing utilized in the fault record gathering and preparation. The overall phase response should be linear within the entire signal passband with phase characteristics matched among different channels. This requirement is hard to achieve with the high power current amplifiers. Depending on the design, these amplifiers normally introduce additional phase delay at higher frequencies. The amount of this delay is often permissible, except for the fact that current channels are no longer matched with their respective voltage waveforms. Voltage amplifiers typically provide wider frequency response. The problem can be resolved by introducing additional input filters in front of the voltage amplifiers. Filters should match the actual current amplifier phase/group delay characteristics.

## V. DFR FILE PROCESSING SOFTWARE

This software consists of the following two modules:

- a. File conversion
- b. File management.

Both of these modules are being developed and will be implemented on the DYNA-TEST simulator.

**a.) File Conversion**

The primary objective of this task is to convert the DFR data files into the IEEE COMTRADE format [4]. The DFR data files are in a binary format and they are different for various recorders. The IEEE format has, as the main choice, an ASCII format. Hence, the conversion facilitates the display of the records using commercially available display software. It also enables the user to exchange data files among different systems. The conversion software for three different binary DFR formats have been written. The choice of the three DFR formats has been made by the utility advisors and reflects the current interest of the advisors. The conversion software will be interfaced with the file management software which is written in MATLAB [9]. All the conversion software is being written in 'C'.

A typical configuration of the DYNA-TEST software is shown in Figure 4.

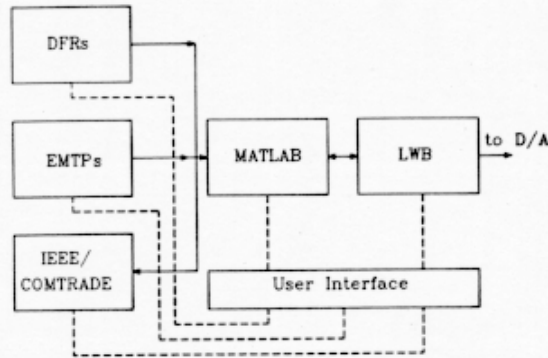

Figure 4. Typical Configuration of the DYNA-TEST Software

This particular software configuration is implemented for the UNIX environment, but a similar set-up will be available in the DOS environment as well. As it can be observed from Figure 4, the file conversion software provides conversions from any of the existing DFR and/or EMTP file formats into the COMTRADE format and vice versa. Also, the file conversion software enables conversion to the MATLAB format. The MATLAB software is used to implement the file management functions. These functions are described in the next section. The LWB software is unique to the UNIX machine used and contains the

D/A driver [10].

The file conversion software is written to support several user selectable options. One is to convert the entire DFR file while the others include conversion of the selected channels with a selected number of sample points per channel.

#### **b.) File Management**

This software is being written using the signal processing software MATLAB [9]. The objective is to manage digital fault recorder and EMTP files effectively. The software will enable one to convert binary waveform data files into ASCII, display and edit the files, perform analysis and finally send the digital data to the I/O subsystem hardware for signal reconstruction. The binary to ASCII conversion is performed by the separate program which is invoked by this software. The software will be menu driven and the user does not need to know any of the MATLAB commands. It can load and display up to four windows. In addition to the menu functions, the software will also have four global functions which will be independent for each displayed window. This software will be made compatible with both DOS and UNIX environments.

The file management software has the following options:

- Load file
- Edit window
- Save window
- Plot file
- Signal processing
- Test initiation
- Global functions.

The Load File option has several sub-options. These sub-options are described next.

One choice is to load the MATLAB data file. The MATLAB data file is a binary file unique to the MATLAB display software. The loading time of these files is considerably less compared to the ASCII and EMTP output files. These files can be printed out in ASCII format after loading. Hence, it is recommended that once an ASCII file has been loaded and edited to get the signals of interest, then it be saved as a MATLAB file. This will save time when the file has to be loaded in successive testing sessions.

Another choice is to load the ASCII data file. The ASCII files are in the IEEE COMTRADE format except for the separators between data points, which have to be blanks. (The IEEE format defines commas as separators). The binary source files could

be having any of the DFR data formats selected so far. This option is to be used only if these files have been previously converted to ASCII using the conversion software.

Yet another choice is to convert binary file to ASCII and load. In this case, the user will be able to convert the binary files to ASCII and load them for display and further analysis. The binary files are the DFR data files. The software invokes the conversion software and will support all the command line parameters implemented in it. The invoking is done by performing a simple system call from the file management software. Hence, one does not need to exit this software to convert binary files.

Finally, an option is to load the EMTP output file.

The edit window option allows the user to select channels for further analysis/processing. The selection can be done either before or after signal processing. The file length can be truncated to delete the unwanted portion of the waveform. One can also edit previously edited files. The software, in its final form, should be able to recognize currents and voltages of different phases. Hence, the user will be guided to select not more than three voltages and currents as a test file.

The save window option enables the user to save the data in any of the four windows. The data can be saved either in ASCII or MATLAB format. As mentioned earlier, files already edited can be saved in the MATLAB format. The ASCII format can be used to exchange data files among the two parties interested in the data.

The plot file option enables printing of the graphics being viewed. If the user is viewing multiple windows then all the windows are printed on the same sheet. The function can be configured to print on any printer supported in MATLAB. Presently, the software has been configured to print on the local EPSON printer and on a Laser printer connected to the Local Area Network.

The signal processing option is the core of the file management software. It will enable the user to interpolate/decimate and filter data file being viewed in any of the windows. It will be possible to display the frequency/power spectrum of a signal. It has to be noted that data files obtained from digital fault recorders may have different sampling frequencies within the same waveform file. The final goal will be to successfully reconstruct such signals. The difficulty lies in separately decimating the parts having different frequencies and then rejoining them for further analysis. In addition, the software can be extended to include other signal analysis functions such as calculation of signal parameters (peak value, rms value, power, symmetrical components).

The test initiation option is the final stage through which data passes before it is fed to the I/O subsystem hardware. The waveform being viewed is sent to the D/A converters and successive stages for signal reconstruction before it is applied to the relay.

The global functions option includes a number of auxiliary screen manipulation functions that are common to almost any graphic software. Typical examples include: multiple

windows; expansion of a window to a full screen; various graphing options; discard window; zoom in/zoom out.

## VI. CONCLUSIONS

Software developments discussed in this paper are aimed at facilitating the use of DFR files for protection relay evaluations. A number of issues associated with the use of existing DFR files are identified. Software to be developed in this project will enable processing of the DFR files for utilization in the digital power system simulator facilities. This software is flexible and user friendly. It is designed to support several DFR and EMTP file formats and can be implemented using either DOS or UNIX environments.

## VII. ACKNOWLEDGEMENTS

The authors would like to acknowledge the contributions of the engineers who are participating in the project as Industry Advisors:

J. Estergalyos - BPA	B. D. Pickett - FPL
C. W. Fromen - HL&P	D. R. Sevcik, HL&P
J. G. Hochiemer - FPL	D. A. Tziouvaras - PG&E
S. M. McKenna -WAPA	

The Texas A&M University graduate students, Mr. P. Namasivayam and Mr. M. Rajani are acknowledged for their contribution to the software development activities reported in this paper.

## VIII. REFERENCES

- [1] M. Kezunovic, A. Abur, Lj. Kojovic, V. Skendzic, H. Singh, C. W. Fromen, D. R. Sevcik, "DYNA-TEST Simulator for Relay Testing-Part I: Design Characteristics," IEEE PES Winter Meeting, Paper No. 91 WM 156-0 *PWRD*, New York, 1991.
- [2] M. Kezunovic, A. Abur, Lj. Kojovic, V. Skendzic, H. Sing, C. W. Fromen, D. R. Sevcik, "DYNA-TEST Simulator for Relay Testing-Part II: Performance Evaluation," IEEE PES Winter Meeting, Paper No. 91 WM 230-3 *PWRD*, New York, 1991.
- [3] L. L. Mankoff, M. Kezunovic, "Protection Relay Workstation: Applications of a Digital Simulator," 44<sup>th</sup> Annual Conf. for Protective Relay Engineers, Texas A&M University, College Station, Texas, April 15-17, 1991.
- [4] "IEEE/COMTRADE - Common Format for Transient Data Exchange," IEEE Power System Relaying Committee, Relaying Channels Subcommittee, W. G. H-5, Draft, January 1990.

- [5] "Electromagnetic Transients Program (EMTP) Rule Book," *EPRI*, EL-6421-L, Vol. 1, 2, Research Project 2149-4, June 1989.
- [6] "Alternative Transients Program (ATP)," Canadian/American EMTP User Group and European EMTP User Organization LEC.
- [7] "Transients Analysis Program for Personal Computers," Microtran Power System Analysis Corporation, Vancouver, British Columbia, Canada, 1988.
- [8] "IEEE Trial Use Standard for Digitizing Waveform Recorders," IEEE Std. 1057, July 1989.
- [9] "PC-MATLAB User's Guide," Math Works Inc., Sherborn, Massachusetts.
- [10] L. McKee, "Laboratory Workbench User's Guide," Revision B., Concurrent Computer Corporation, Massachusetts, October 1988.